



WBP8E3-54C1@WBP8F3-54C1

10Gb/s Bi-Di SFP+ Transceiver Module with DDM function

Features

- Supports 9.95Gb/s to 11.3Gb/s bit rates
- Hot-pluggable SFP+ footprint
- Single LC for Bi-directional Transmission
- Maximum link length of 10km
- Built-in 1270/1330 WDM Filter
- Uncooled 1270nm CWDM DFB Laser.
- Power dissipation <1.5W
- No Reference Clock required
- Built-in digital diagnostic functions
- Temperature range 0°C to 70°C
- Very low EMI and excellent ESD protection
- RoHS Compliant Part

Applications

- 10GBASE-LR/LW Ethernet
- SONET OC-192 / SDH
- 10G Fiber Channel

Standard

- Compliant with SFF-8431 Rev3.0
- Compliant with SFF-8472 Rev10.2
- Compliant with IEEE802.3ae 10GBASE

Ordering Information

Specifications										
Part No	packa ge	Data rate	Tx	Optical Power	Rx	Sen OMA	Temp	Reach	other	Application
WBP8E3-54C1	SFP+	10Gbps	1270nm DFB	-1~-6dBm	1330nm PIN	<-14.5dBm	0~70°C	10km	DDM	10GBASE-LR/LW 8G/10GFC
WBP8F3-54C1	SFP+	10Gbps	1330nm DFB	-1~-6dBm	1330nm PIN	<-14.5dBm	0~70°C	10km	DDM	10GBASE-LR/LW 8G/10GFC



Descriptions

The WBP8E3-54C1@WBP8F3-54C1 Bi-directional 10Gb/s (SFP+) transceivers are compliant with the current SFP+ Multi-Source Agreement (MSA) Specification. They comply with 10GBASE-LR/LW Ethernet, SONET OC-192 / SDH and 10G Fiber Channel 1200-SM-LL-L. Digital diagnostics functions are available via a 2-wire serial interface, as specified in the SFP+ MSA

• Absolute Maximum Ratings

Parameter	Symbol	Min.	Typical	Max.	Unit
Storage Temperature	T_S	-40		+85	° C
Supply Voltage	$V_{CC,T, R}$	-0.5		4	V
Relative Humidity	RH	0		85	%

• Recommended Operating Environment:

Parameter	Symbol	Min.	Typical	Max.	Unit
Case operating Temperature	T_C	-5		+70	° C
Supply Voltage	$V_{CCT, R}$	+3.135		+3.465	V
Supply Current	I_{CC}			350	mA
Power Dissipation	P_D			1.5	W

• Electrical Characteristics ($T_{OP} = 0$ to 70 °C, $V_{CC} = 3.135$ to 3.465 Volts)

Parameter	Symbol	Min	Typ	Max	Unit	Note
Transmitter:						
Differential input voltage swing		180		700	mVpp	1
Transmit Disable Input	H	V_{IH}	2.0	$V_{CC}+0.3$	V	
	L	V_{IL}	0	0.8	V	
Transmit Enable Output	H	V_{OH}	2.4	$V_{CC}+0.3$	V	
	L	V_{OL}	0	0.4	V	2
Input Differential Impedance	Z_{in}	80	100	120	Ω	
Receiver						
Differential output voltage swing		300		850	mVpp	3
LOS Output	H	V_{OH}	2.4	$V_{CC}+0.3$	V	2
	L	V_{OL}	0	0.4	V	
Output Differential Impedance	Z_{on}	80	100	120	Ω	

Notes:

Note 1) TD+/- are internally AC coupled with 100 Ω differential termination inside the module.

Note 2) Tx Fault and Rx LOS are open collector outputs, which should be pulled up with 4.7k to 10k Ω resistors on the host board. Pull up voltage between 2.0V and $V_{CC}+0.3V$.



Note 3) RD+/- outputs are internally AC coupled, and should be terminated with 100Ω (differential) at the user SERDES.

• **Optical Parameters(T_{OP} = 0 to 70°C, VCC = 3.135 to 3.465 Volts)**

Parameter		Symbol	Min	Typ	Max	Unit	Ref.
Transmitter							
Bit Rate		BR	9.9		11.3	Gb/s	
Optical Wavelength	WBP8E3-54C1	λ	1260	1270	1280	nm	
	WBP8F3-54C1	λ	1320	1330	1340	nm	
Average output power		P _o	-6		-1	dBm	
Optical Extinction Ratio		ER	3.5			dB	
Spectral width		Δλ			1	nm	
Side Mode Suppression Ratio		SMSR	30			dB	
Optical Eye Mask			Compliant with IEEE802.3ae				
Receiver							
Bit Rate		BR	9.9		11.3	Gb/s	
Optical Wavelength	WBP8E3-54C1	λ	1320	1330	1340	nm	
	WBP8F3-54C1	λ	1260	1270	1280	nm	
Receiver Sensitivity		Sen			-14	dBm	1
Maximum Input Power		P _{MAX}	0			dBm	
LOS De-Assert		LOS _D			-15	dBm	
LOS Assert		LOS _A	-25			dBm	
LOS Hysteresis		LOS _H	0.5		4	dB	

Notes:

Note 1) Measured with a PRBS of 2³¹-1 at 1 x 10⁻¹² BER and 3.5 dB extinction ratio.

• **Pin Assignment**

Diagram of Host Board Connector Block Pin Numbers and Name

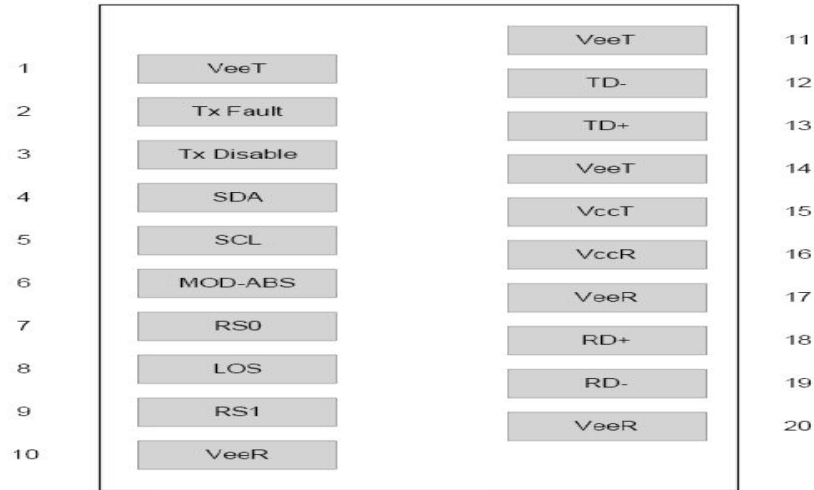

• Pin Function Definitions

PIN #	Name	Function	Notes
1	VeeT	Module transmitter ground	1
2	Tx Fault	Module transmitter fault	2
3	Tx Disable	Transmitter Disable; Turns off transmitter laser output	3
4	SDL	2 wire serial interface data input/output (SDA)	
5	SCL	2 wire serial interface clock input (SCL)	
6	MOD-ABS	Module Absent, connect to VeeR or VeeT in the module	2
7	RS0	Rate select0, optionally control SFP+ receiver. When high, input data rate >4.5Gb/s; when low, input data rate <=4.5Gb/s	
8	LOS	Receiver Loss of Signal Indication	4
9	RS1	Rate select0, optionally control SFP+ transmitter. When high, input data rate >4.5Gb/s; when low, input data rate <=4.5Gb/s	
10	VeeR	Module receiver ground	1
11	VeeR	Module receiver ground	1
12	RD-	Receiver inverted data out put	
13	RD+	Receiver non-inverted data out put	
14	VeeR	Module receiver ground	1
15	VccR	Module receiver 3.3V supply	
16	VccT	Module transmitter 3.3V supply	
17	VeeT	Module transmitter ground	1
18	TD+	Transmitter inverted data out put	
19	TD-	Transmitter non-inverted data out put	
20	VeeT	Module transmitter ground	1

Note 1) The module ground pins shall be isolated from the module case.

Note 2) This pin is an open collector/drain output pin and shall be pulled up with 4.7K-10Kohms to Host_Vcc on the host board.



Note 3) This pin shall be pulled up with 4.7K-10Kohms to VccT in the module.

Note 4) This pin is an open collector/drain output pin and shall be pulled up with 4.7K-10Kohms to Host_Vcc on the host board.

• SFP Module EEPROM Information and Management

The SFP modules implement the 2-wire serial communication protocol as defined in the SFP -8472. The serial ID information of the SFP modules and Digital Diagnostic Monitor parameters can be accessed through the I²C interface at address A0h and A2h. The memory is mapped in Table 1. Detailed ID information (A0h) is listed in Table 2. And the DDM specification at address A2h. For more details of the memory map and byte definitions, please refer to the SFF-8472, “Digital Diagnostic Monitoring Interface for Optical Transceivers”. The DDM parameters have been internally calibrated.

Table 1. Digital Diagnostic Memory Map (Specific Data Field Descriptions)

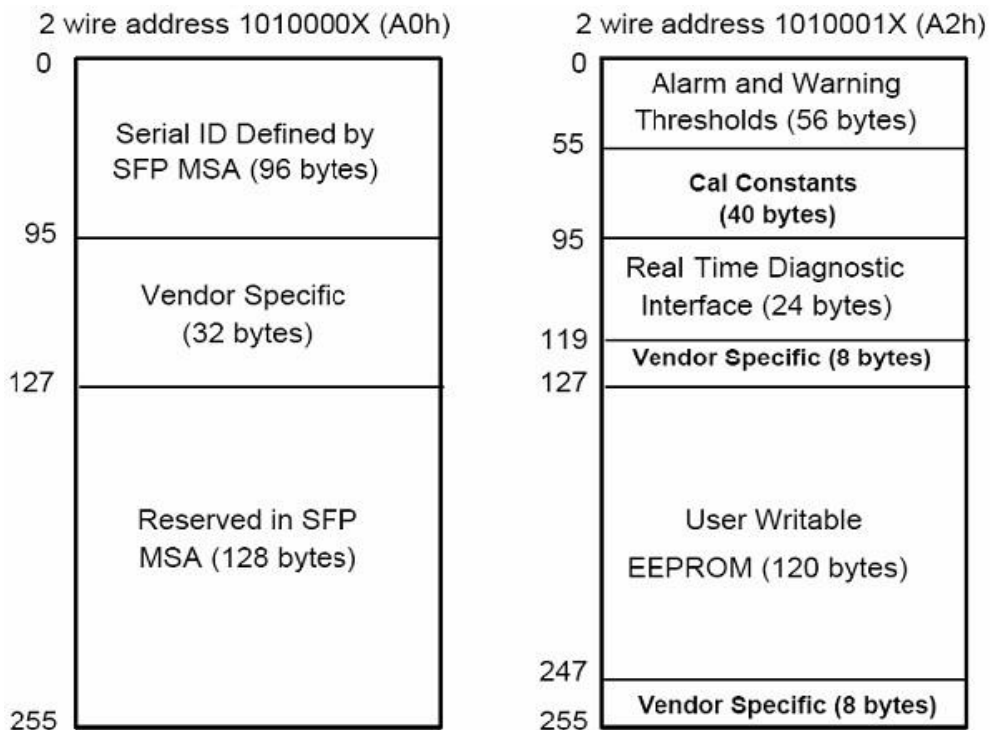



Table 2 - EEPROM Serial ID Memory Contents (A0h)

Data Address	Length (Byte)	Name of Length	Description and Contents
Base ID Fields			
0	1	Identifier	Type of Serial transceiver (03h=SFP)
1	1	Reserved	Extended identifier of type serial transceiver (04h)
2	1	Connector	Code of optical connector type (07=LC)
3-10	8	Transceiver	10G Base-LR
11	1	Encoding	64B/66B
12	1	BR, Nominal	Nominal baud rate, unit of 100Mbps
13-14	2	Reserved	(0000h)
15	1	Length(9um)	Link length supported for 9/125um fiber, units of 100m
16	1	Length(50um)	Link length supported for 50/125um fiber, units of 10m
17	1	Length(62.5um)	Link length supported for 62.5/125um fiber, units of 10m
18	1	Length(Copper)	Link length supported for copper, units of meters
19	1	Reserved	
20-35	16	Vendor Name	SFP vendor name:
36	1	Reserved	
37-39	3	Vendor OUI	SFP transceiver vendor OUI ID
40-55	16	Vendor PN	Part Number: "WBP8E3-54C1@WBP8F3-54C1" " (ASCII)
56-59	4	Vendor rev	Revision level for part number
60-62	3	Reserved	
63	1	CCID	Least significant byte of sum of data in address 0-62
Extended ID Fields			
64-65	2	Option	Indicates which optical SFP signals are implemented (001Ah = LOS, TX_FAULT, TX_DISABLE all supported)
66	1	BR, max	Upper bit rate margin, units of %
67	1	BR, min	Lower bit rate margin, units of %
68-83	16	Vendor SN	Serial number (ASCII)
84-91	8	Date code	Manufacturing date code
92-94	3	Reserved	
95	1	CCEX	Check code for the extended ID Fields (addresses 64 to 94)
Vendor Specific ID Fields			
96-127	32	Readable	
128-255	128	Reserved	Reserved for SFF-8079

• **Digital Diagnostic Monitor Characteristics**

Data Address	Parameter	Accuracy	Unit
96-97	Transceiver Internal Temperature	±3.0	° C
98-99	VCC3 Internal Supply Voltage	±3.0	%
100-101	Laser Bias Current	±10	%
102-103	Tx Output Power	±3.0	dBm
104-105	Rx Input Power	±3.0	dBm

• **Regulatory Compliance**

The WBP8E3-54C1@WBP8F3-54C1 complies with international Electromagnetic Compatibility (EMC) and international safety requirements and standards (see details in Table following).

Electrostatic Discharge (ESD) to the Electrical Pins	MIL-STD-883E Method 3015.7	Class 1(>1000 V)
Electrostatic Discharge (ESD) to the Single LC Receptacle	IEC 61000-4-2 GR-1089-CORE	Compatible with standards
Electromagnetic Interference (EMI)	FCC Part 15 Class B EN55022 Class B (CISPR 22B) VCCI Class B	Compatible with standards
Laser Eye Safety	FDA 21CFR 1040.10 and 1040.11 EN60950, EN (IEC) 60825-1,2	Compatible with Class 1 laser product.

• **Recommended Circuit**

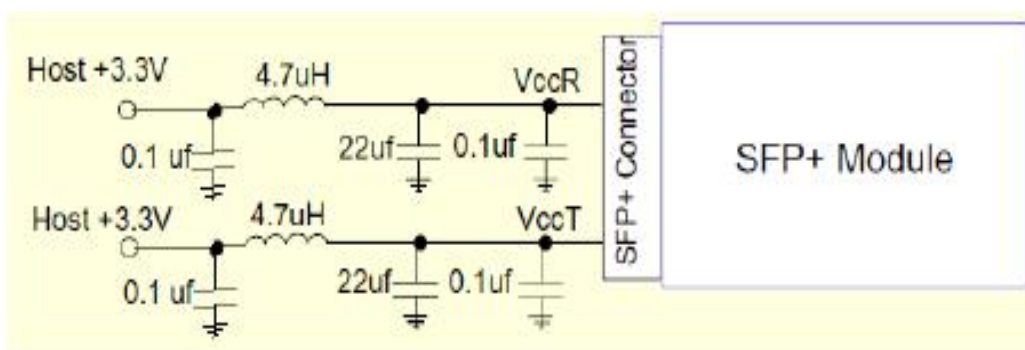

Recommended Host Board Power Supply Circuit

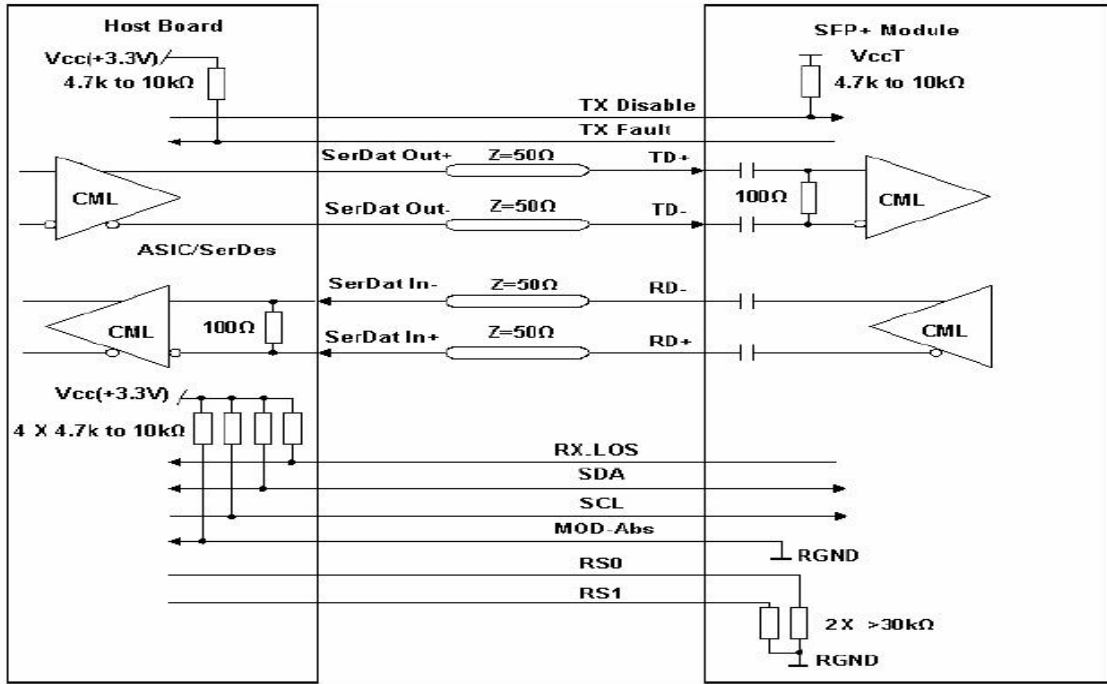

Recommended High-speed Interface Circuit

• Mechanical Dimensions

