



WDS443-57C1

1.25Gb/s SFP Transceiver Module with DDM function

Features

- Up to 1.25Gbps data rate
- 1310nm DFB laser transmitter
- Pin photo-detector
- Up to 40km on 9/125um SMF
- Hot-pluggable SFP footprint
- LC pluggable optical interface
- Low power dissipation
- Metal enclosure, for lower EMI
- RoHS compliant and lead-free
- Single +3.3V power supply
- Support Digital Diagnostic Monitoring interface
- Compliant with SFF-8472
- Case operating temperature 0°C to 70°C

Applications

- Gigabit Ethernet
- Gigabit Fiber Channel
- Other optical link

Standard

- Compliant with SFP MSA (INF-8074i)
- Compliant with SFF-8472 V9.5
- Compliant with IEEE802.3z Gigabit Ethernet

Ordering information

Part No	Specification								
	Package	Data rate	Laser	Optical Power	Detector	Sensitivity	Temp	Reach	Interface
WDS443-57C1	SFP	1.25Gb/s	1310 DFB	-2~3dBm	PIN	<-24dBm	0~70°C	40KM	LC



Descriptions

The WDS443-57C1 Small Form Factor Pluggable (SFP) transceivers are compatible with the Small Form Factor Pluggable Multi-Sourcing Agreement (MSA). The transceiver consists of five sections: the LD driver, the limiting amplifier, the digital diagnostic monitor, the 1310nm DFB laser and the PIN photo-detector. The module data link up to 40KM in 9/125um single mode fiber.

The optical output can be disabled by a TTL logic high-level input of Tx Disable, and the system also can disable the module via I2C. Tx Fault is provided to indicate that degradation of the laser. Loss of signal (LOS) output is provided to indicate the loss of an input optical signal of receiver or the link status with partner. The system can also get the LOS (or Link)/Disable/Fault information via I2C register access.

Pin Descriptions

Pin	Symbol	Name/Description	Ref.
1	VEET	Transmitter Ground (Common with Receiver Ground)	1
2	TFAULT	Transmitter Fault.	
3	TDIS	Transmitter Disable. Laser output disabled on high or open.	2
4	MOD_DEF(2)	Module Definition 2. Data line for Serial ID.	3
5	MOD_DEF(1)	Module Definition 1. Clock line for Serial ID.	3
6	MOD_DEF(0)	Module Definition 0. Grounded within the module.	3
7	Rate Select	No connection required	4
8	LOS	Loss of Signal indication. Logic 0 indicates normal operation.	5
9	VEER	Receiver Ground (Common with Transmitter Ground)	1
10	VEER	Receiver Ground (Common with Transmitter Ground)	1
11	VEER	Receiver Ground (Common with Transmitter Ground)	1
12	RD-	Receiver Inverted DATA out. AC Coupled	
13	RD+	Receiver Non-inverted DATA out. AC Coupled	
14	VEER	Receiver Ground (Common with Transmitter Ground)	1
15	VCCR	Receiver Power Supply	
16	VCCT	Transmitter Power Supply	
17	VEET	Transmitter Ground (Common with Receiver Ground)	1
18	TD+	Transmitter Non-Inverted DATA in. AC Coupled.	
19	TD-	Transmitter Inverted DATA in. AC Coupled.	
20	VEET	Transmitter Ground (Common with Receiver Ground)	1



Notes:

1. Circuit ground is internally isolated from chassis ground.
2. Laser output disabled on $T_{DIS} > 2.0V$ or open, enabled on $T_{DIS} < 0.8V$.
3. Should be pulled up with 4.7k - 10kohms on host board to a voltage between 2.0V and 3.6V.
MOD_DEF(0) pulls line low to indicate module is plugged in.
4. This is an optional input used to control the receiver bandwidth for compatibility with multiple data rates (most likely Fiber Channel 1x and 2x Rates). If implemented, the input will be internally pulled down with $> 30k\Omega$ resistor. The input states are:
Low (0 - 0.8V): Reduced Bandwidth
($>0.8V, < 2.0V$): Undefined
High (2.0 - 3.465V): Full Bandwidth
Open: Reduced Bandwidth
5. LOS is open collector output. Should be pulled up with 4.7k - 10kohms on host board to a voltage between 2.0V and 3.6V. Logic 0 indicates normal operation; logic 1 indicates loss of signal.

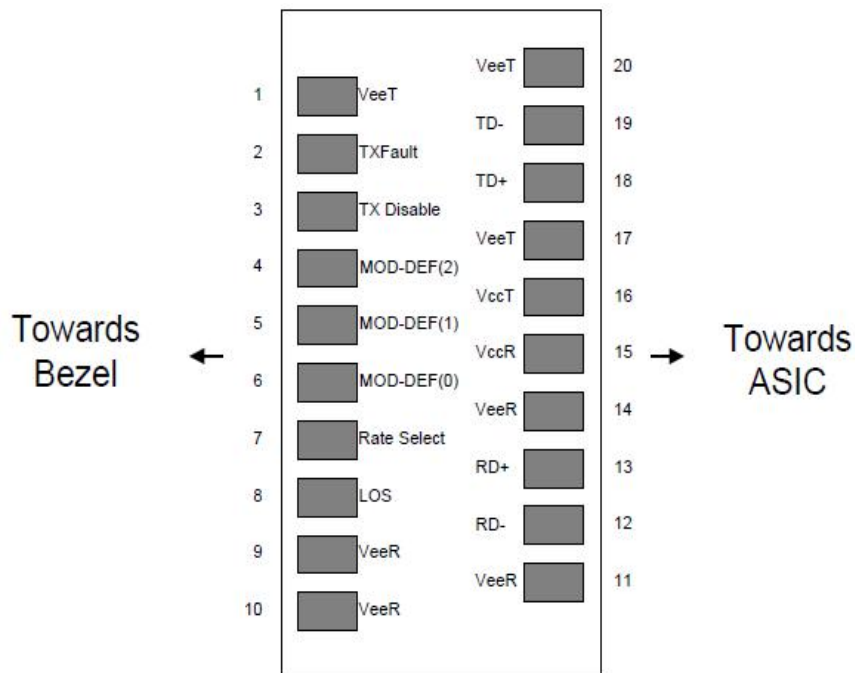

Figure 2: Pin-out of Connector Block on Host Board



Absolute Maximum Ratings

Parameter	Symbol	Min.	Typ.	Max.	Unit	Note
Storage Temperature	Ts	-40		85	°C	
Storage Ambient Humidity	HA	5		95	%	
Power Supply Voltage	VCC	-0.5		4	V	
Signal Input Voltage		-0.3		Vcc+0.3	V	
Receiver Damage Threshold		5			dBm	

Recommended Operating Conditions

Parameter	Symbol	Min.	Typ.	Max.	Unit	Note
Case Operating Temperature	Tcase	0		70	°C	
Ambient Humidity	HA	5		70	%	Non-condensing
Power Supply Voltage	VCC	3.13	3.3	3.47	V	
Power Supply Current	ICC			280	mA	
Power Supply Noise Rejection				100	mVp-p	100Hz to 1MHz
Data Rate			1.25		Gbps	TX Rate/RX Rate
Transmission Distance			40		KM	
Coupled Fiber		Single mode fiber				9/125um SMF

Specification of Transmitter

Parameter	Symbol	Min.	Typ.	Max.	Unit	Note
Average Output Power	POUT	-2		+3	dBm	
Extinction Ratio	ER	9			dB	
Center Wavelength	λC	1290	1310	1330	nm	
Spectrum Width (RMS)	σ			1	nm	TX: 1310nm DFB
Transmitter OFF Output Power	POff			-45	dBm	
Differential Line Input Impedance	RIN	90	100	110	Ohm	
Total Jitter (Peak-Peak)	tJ			128	ps	Note (1)
Output Eye Mask	Compliant with IEEE802.3Z (class 1 laser safety)					Note (2)

Note (1): Measure at 2⁷-1 NRZ PRBS pattern

Note (2): Transmitter eye mask definition

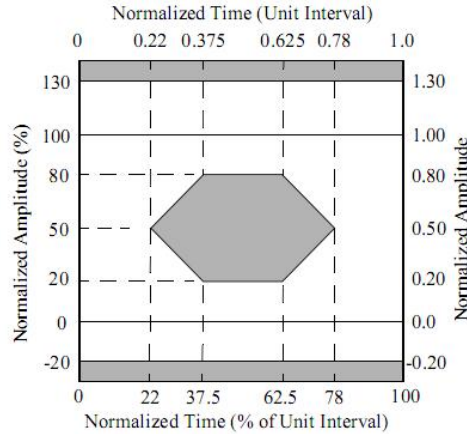

Specification of Receiver

Parameter	Symbol	Min.	Typ.	Max.	Unit	Note
Input Optical Wavelength	λ IN	1270	1310	1610	nm	
Receiver Sensitivity	PIN			-24	dBm	Note (1)
Input Saturation Power (Overload)	PSAT	-3			dBm	
Los Of Signal Assert	PA	-37			dBm	
Los Of Signal De-assert	PD			-25	dBm	Note (2)
LOS Hysteresis	PA-PD	0.5		7	dB	

Note (1): Measured with Light source 1550nm(1310nm), ER=10dB; BER = $<10^{-10}$ @PRBS=2⁷-1 NRZ

Note (2): When LOS de-asserted, the RX data+/- output is High-level (fixed)

Electrical Interface Characteristics

Parameter	Symbol	Min.	Typ.	Max.	Unit	Note
Transmitter						
Total Supply Current	ICC			A	mA	Note (1)
Transmitter Disable Input-High	VDISH	2		V _{cc} +0.3	V	
Transmitter Disable Input-Low	VDISL	0		0.8	V	
Transmitter Fault Input-High	VDISL	2		V _{cc} +0.3	V	
Transmitter Fault Input-Low	VTxFH	0		0.8	V	
Receiver						
Total Supply Current	ICC			B	mA	Note (1)
LOSS Output Voltage-High	VLOSH	2		V _{cc} +0.3	V	LVTTTL
LOSS Output Voltage-Low	VLOSL	0		0.8	V	



Note (1): $A \text{ (TX)} + B \text{ (RX)} = 280\text{mA}$ (Not include termination circuit)

Digital Diagnostic Functions

WDS443-57C1 transceivers support the 2-wire serial communication protocol as defined in the SFP MSA. It is very closely related to the E2PROM defined in the GBIC standard, with the same electrical specifications.

The standard SFP serial ID provides access to identification information that describes the transceiver's capabilities, standard interfaces, manufacturer, and other information.

Additionally, Net-Light SFP transceivers provide a unique enhanced digital diagnostic monitoring interface, which allows real-time access to device operating parameters such as transceiver temperature, laser bias current, transmitted optical power, received optical power and transceiver supply voltage. It also defines a sophisticated system of alarm and warning flags, which alerts end-users when particular operating parameters are outside of a factory set normal range.

The SFP MSA defines a 256-byte memory map in E2PROM that is accessible over a 2-wire serial interface at the 8 bit address 1010000X (A0h). The digital diagnostic monitoring interface makes use of the 8 bit address 1010001X (A2h), so the originally defined serial ID memory map remains unchanged. The interface is identical to, and is thus fully backward compatible with both the GBIC Specification and the SFP Multi Source Agreement.

The operating and diagnostics information is monitored and reported by a Digital Diagnostics Transceiver Controller (DDTC) inside the transceiver, which is accessed through a 2-wire serial interface. When the serial protocol is activated, the serial clock signal (SCL, Mod Def 1) is generated by the host. The positive edge clocks data into the SFP transceiver into those segments of the E2PROM that are not write-protected. The negative edge clocks data from the SFP transceiver. The serial data signal (SDA, Mod Def 2) is bi-directional for serial data transfer. The host uses SDA in conjunction with SCL



Digital Diagnostic Memory Map

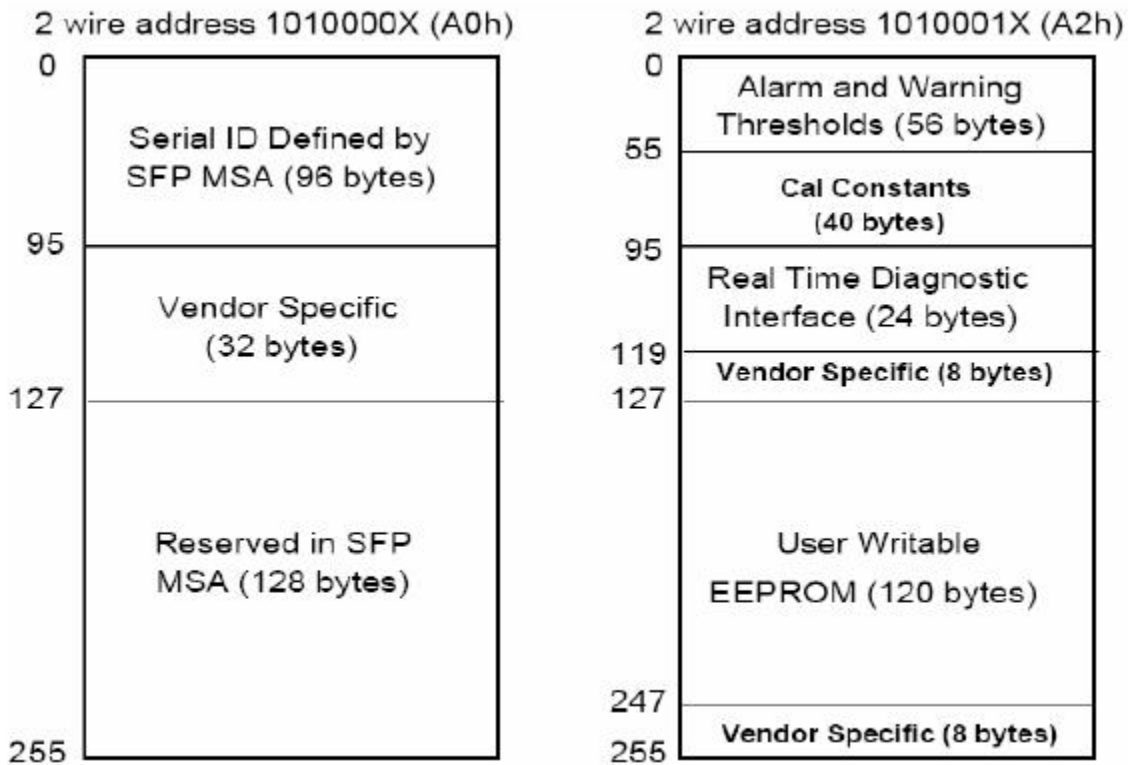

EEPROM Serial ID Memory Contents

Accessing Serial ID Memory uses the 2 wire address 1010000X(A0). Memory Contents of Serial ID are shown in the table below.

WDS443-57C1				
Data Address	Size (Bytes)	Name of Field	Contents(Hex)	Description
BASE ID FIELDS				
0	1	Identifier	03	SFP
1	1	EXT.Identifier	04	SFP function is defined by



				Serial ID only
2	1	Connector	07	LC Connector
3--10	8	Transceiver		Transceiver Code
11	1	Encoding	03	NRZ
12	1	BR, Norminal	0C	1200Mbps
13	1	Reserved	00	
14	1	Length(9um, km)	28	Transceiver transmit Distance (40km)
15	1	Length(9um)	FF	
16	1	Length(50um)	00	Not compliant
17	1	Length(62.5um)	00	
18	1	Length(Copper)	00	
19	1	Reserved	00	
20--35	16	Vendor name		Net-Light (ASCII)
36	1	Reserved	00	
37--39	3	Vendor OUI	00 00 00	
40--55	16	Vendor PN		WDS443-57C1 (ASCII)
56--59	4	Vendor REV	00 00 00 00	
60--61	2	Wavelength		Transceiver wavelength
62	1	Reserved	00	
63	1	CC_BASE	Check Sum	Check code for Base ID Fields
EXTEDNDED ID FIELDS				
64--65	2	Options	00 1A	TX_DISABLE TX_FAULT and Losss of Signal implemented
66	1	BR, max	00	
67	1	BR, min	00	
68--83	16	Vendor SN	31 32 33 34 35 36 37 38 20 20 20 20 20 20 20 20	Serial Number of transceiver (ASCII). For example :12345678
84--91	8	Data code	30 35 31 30 31 31 20 20	Data code :051011
92	1	Diagnostic Monitoring Type	58	Diagnostics (EXT. Cal)
93	1	Enhanced Options	B0	Diagnostics (Optional Alarm /warning flags ,soft TX_Fault and RX_LOS monitoring
94	1	SFF-8472	02	Diagnostics



		Compliance		(SFF-8472 Rev9.5)
95	1	CC_EXT	Check Sum	Check sum for Extended ID Field
VENDOR SPECIFIC ID FIELDS				
96--255	160	Vendor Specific		

Digital Diagnostic Monitoring Information

Parameter	unit	Actual Value	Note
Transceiver Temperature	°C	+/-3	
Power Supply Voltage	%	+/-3	
Tx Bias Current	%	+/-10	
Tx Optical Power	dBm	+/-3	
Rx Optical Power	dBm	+/-3	

Mechanical Specifications (Unit: mm)

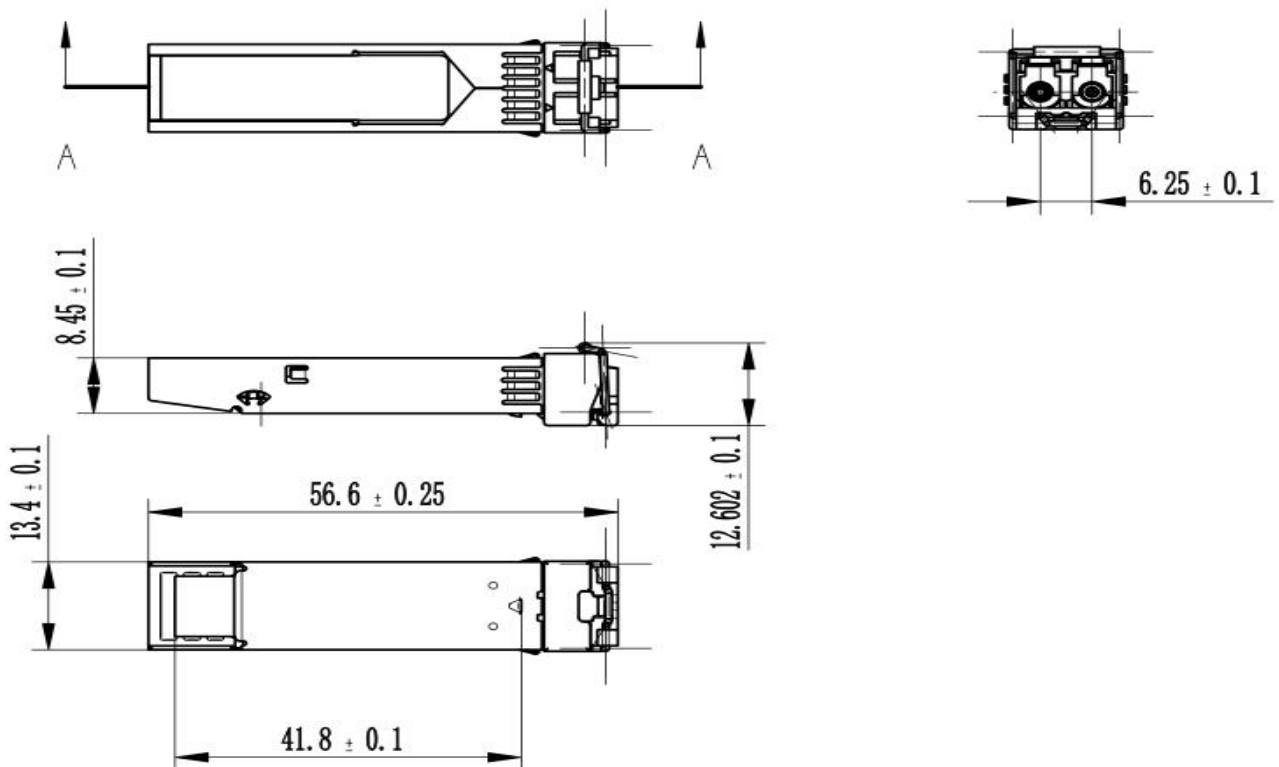



Regulatory Compliance

Feature	Reference	Performance
Electrostatic discharge (ESD)	IEC/EN 61000-4-2	Compatible with standards
Electromagnetic Interference (EMI)	FCC Part 15 Class B EN 55022 Class B (CISPR 22A)	Compatible with standards
Laser Eye Safety	FDA 21CFR 1040.10, 1040.11 IEC/EN 60825-1, 2	Class 1 laser product
Component Recognition	IEC/EN 60950 , UL	Compatible with standards
ROHS	2002/95/EC	Compatible with standards
EMC	EN61000-3	Compatible with standards