



## WDP813-52C1

### 10GB/s 300m SFP+ 850nm Transceiver with DDM function

#### Features

- Compliant to SFP+ MSA
- Fully ROHS Compliant
- All metal housing for superior EMI performance
- Data rate from 8.5Gbps to 10Gbps
- VCSEL 850nm Laser
- High sensitivity PIN photodiode and TIA
- Up to 300m
- LC duplex connector
- Hot pluggable 20pin connector
- Low power consumption < 1.0W
- 0°C to 70°C operating wide temperature range
- Single +3.3V±5% power supply
- Digital Diagnostic Monitoring sff-8472 Rev10.2 compliant
- Real time monitoring of :
  - Transmitted optical power
  - Received optical power
  - Laser bias current
  - Temperature
  - Supply voltage

#### Applications

- 10GBASE -SR
- 8.5G/10.5G/s Fiber Channel

#### Standard

- IEEE 802.3ae 10GBASE - SR
- SFF-8431 Rev 3.0
- SFF-8472 Rev 10.2
- FC-PI-4 Rev 7.0

#### Ordering Information

Specifications										
Part No	packa ge	Data rate	Tx	Optical Power	Rx	Sen	Top	Reach	other	Application
WDP813-52C1	SFP+	10Gbps	850nm	-7.3~ -1dBm	PIN	<-9.9dBm	0~70°C	300m	DDM	10GBASE-SR



## Descriptions

The WDP813-52C1 850nm 10Gigabit Transceiver is designed to transmitter and receive serial optical data over multi mode optical fiber with 300m.

They are compliant with SFF-8431, SFF-8472 ,FC-PI-4 Rev7.0 and IEEE802.3ae 10GBASE-SR .

The transmitter convets serial CML electrical data into serial optical data compliant with the IEEE802.3ae standard. An open collector compatible Transmit Disable (Tx\_Dis) is provided .When Tx\_Dis is asserted high, Transmitter is turned off .

The receiver converts serial optical data into serial CML electrical data .An open collector compatible loss of signal is provided .The RX\_LOS signal indicates insufficient optical power for reliable signal reception at the receiver. Digital diagnostics functions are available via 2-wire serial interface ,as specified in sff-8472 .

The optical output can be disabled by a TTL logic high-level input of Tx Disable, and the system also can disable the module via I2C. Tx Fault is provided to indicate that degradation of the laser. Loss of signal (LOS) output is provided to indicate the loss of an input optical signal of receiver or the link status with partner. The system can also get the LOS (or Link)/Disable/Fault information via I2C register access.

## Block Diagram

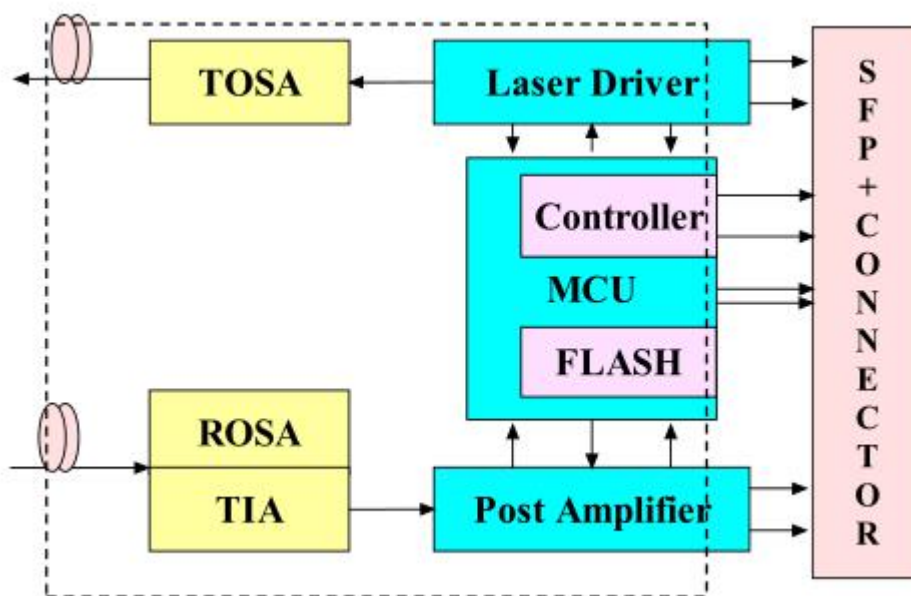

Figure 1. Transceiver functional diagram



## Absolute Maximum Ratings

Parameter	Symbol	Min.	Typ.	Max.	Unit	Note
Storage Temperature	Ts	-40		85	°C	
Storage Ambient Humidity	HA	5		95	%	

## Recommended Operating Conditions

Parameter	Symbol	Min.	Typ.	Max.	Unit	Note
Case Operating Temperature	Tcase	0		70	°C	
Ambient Humidity	HA	5		70	%	Non-condensing
Power Supply Voltage	VCC	3.13	3.3	3.47	V	
Bit Rate	BR	8.5	10.3	10.5	Gb/s	
Bit Error Ratio	BER				10-12	
Max Supported link Length						
Coupled Fiber		Multi mode fiber				50/125um MMF

## Electrical Characteristics (Tc = 0°C to 70 °C and Vcc= 3.14 to 3.46)

Parameter	Symbol	Min.	Typ.	Max.	Unit	Note
Supply Voltage	Vcc	3.14	3.3	3.46	V	
Supply Current	Icc			300	mA	
<b>Transmitter</b>						
Input Differential Impedance	Rin	80	100	120	Ω	
Differential Data Input Swing	Vin	100		1000	mVp-p	
Transmit Disable Voltage	Vdis	2			V	
Transmit Enable Voltage	Ven	Vee		Vee+0.8	V	
Transmit Fault Assert Voltage	Vfa	2.2			V	
Transmit Fault De-Assert Voltage	Vfda	Vee		Vee+0.4	V	
<b>Receiver</b>						
Differential Data Output Swing	Vod	300	600	840	mVp-p	
Output Rise Time	Trise		25		ps	20%~80%
Output Fall Time	Tfall		25		ps	20%~80%
LOS Fault	Vlosft	2		Vcc	V	
LOS Normal	Vlosnr	Vee		Vee+0.8	V	



Optical Characteristics ( $T_c = 0^\circ\text{C}$  to  $70^\circ\text{C}$  and  $V_{cc} = 3.14\text{V}$  to  $3.46\text{V}$ )

Parameter	Symbol	Min.	Typ.	Max.	Unit	Note
<b>Transmitter</b>						
Nominal Wavelength	$\lambda$	840	850	860	nm	
Spectral width	$\Delta \lambda$			0.85	nm	
Optical Modulation Amplitude	Poma	-5.4			dBm	
Optical Output Power	Pav	-7.3		-1	dBm	
Extinction Ratio	ER	3.5			dB	
Transmitter and Dispersion Penalty	TDP			3.9	dB	
Launch Power in OMA Minus TDP		-6.2			dBm	
Average Launch Power of OFF Transmitter	Poff			-35	dBm	
Relative Intensity Noise	Rin			-128	dB/HZ	
Optical Return Loss Tolerance	ORLT			12	dB	
<b>Receiver</b>						
Center Wavelength	$\lambda$	840	850	860	nm	
Average Receiver Power	Pavg			-9.9	dBm	1
Receiver Optial Return Loss	ORL	12			dB	
Receiver Saturation	Rsat	0			dBm	
Los Assert LOS	LOSd	-30			dBm	
Los De-Assert LOS	LOSa			-12	dBm	
Los Hysteresis		0.5			dB	

**Notel:** Sensitivity for 10.3G PRBS 2\*23-1 and BER better than or equal to  $10E-12$



## Pin function definitions

Table 1: Transceiver pin descriptions

Pin Number	Symbol	Name	Description
1, 17, 20	VeeT	Transmitter Signal Ground	These pins should be connected to signal ground on the host board.
2	TX Fault	Transmitter Fault Out (OC)	Logic "1" Output=Laser Fault(Laser off before t_fault) Logic "0" Output=Normal Operation This pin is open collector compatible, and should be pulled up to Host Vcc with a 10kΩ resistor
3	TX Disable	Transmitter Disable In (LVTTL)	Logic "1" Input(or no connection)=laser off Logic "0" Input = Laser on This pin is internally pulled up to VccT with a 10kΩ resistor
4	SDA	Module Definition Identifiers	Serial ID with SFF-8472 Diagnostics
5	SCL		Module Definition pins should be pulled up to Host Vcc with 10 kΩ resistors.
6	MOD-ABS		
7	RS0	ReceiverRateSelect (LVTTL)	These pins have an internal 30 kΩ pull-down to ground.
9	RS1	Transmitter Rate Select (LVTTL)	A Signal on either of these pins will not affect module performance.
8	LOS	Loss of signal Out(OC)	Sufficient optical signal for potential BER<1x10 <sup>-12</sup> =Logic "0" Insufficient optical signal for potential BER<1x10 <sup>-12</sup> =Logic "1" This pin is open collector compatible , and should be pulled up to Host Vcc with a 10 kΩ resistor
10, 11, 14	VeeR	Receiver Signal Ground	This pins should be connected to signal ground on the host board.
12	RD-	Receiver Negative Data Out (CML)	Light on = Logic "0" Output Receiver Data output is internally AC coupled and series terminated with a 50Ω resistor.
13	RD+	Receiver Positive Data Out (CML)	Light on = Logic "1" Output Receiver Data output is internally AC coupled and series terminated with a 50Ω resistor.
15	VccR	Receiver Power Supply	This pin should be connected to a filtered +3.3V power supply on the host board . See Figure3. Recommended power supply filter
16	VccT	Transmitter Power Supply	This pin should be connected to a filtered +3.3V power supply on the host board . See Figure3. Recommended power supply filter



18	TD+	Transmitter Positive Data In (CML)	Logic "1" Input =light on Transmitter Data inputs are internally AC coupled and terminated with a differential 100Ω resistor
19	TD-	Transmitter Negative Data In(CML)	Logic "0" Input =light on Transmitter Data inputs are internally AC coupled and terminated with a differential 100Ω resistor

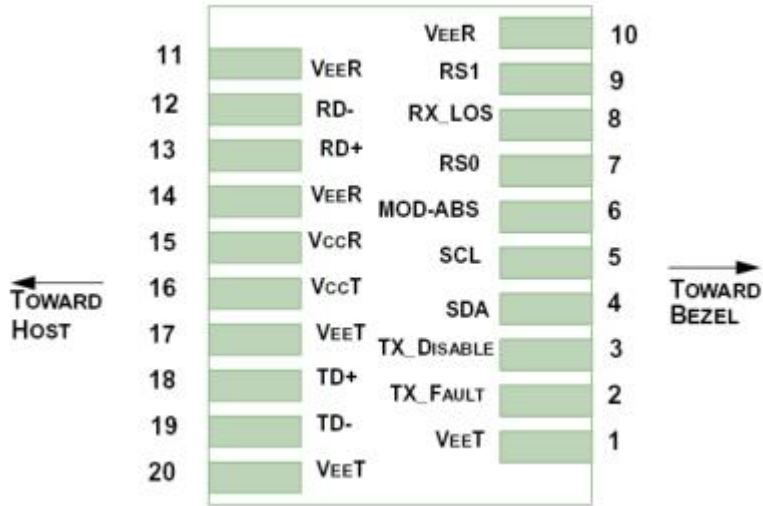

Figure 2. Pin function definitions

**Typical application circuit**

Recommended “Typical Application Schematics” are shown in Figure 3

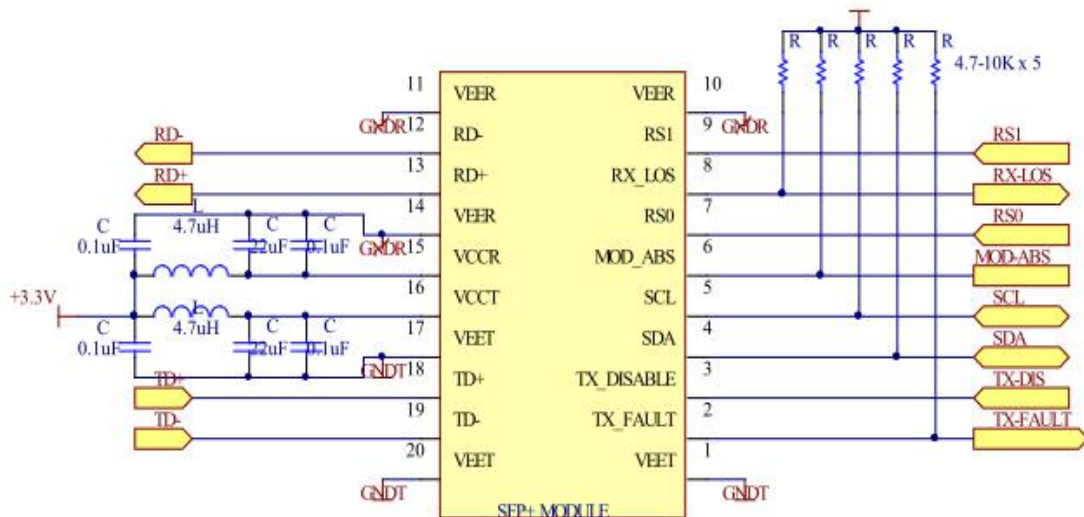

Figure 3. Typical application schematics

**Electrostatic Discharge (ESD)**



The WDP813-52C1 is compatible with ESD levels found in typical manufacturing and operating environments as described in Table 2. In the normal handling and operation of optical transceivers, ESD is of concern in two circumstances.

The first case is during handling of the transceiver prior to insertion into an SFP+ compliant cage. To protect the device, it's important to use normal ESD handling pre-cautions. These include use of grounded wrist straps, work-benches and floor wherever a transceiver is handled

The second case to consider is static discharges to the exterior of the host equipment chassis after installation. If the optical interface is exposed to the exterior of host equipment cabinet, the transceiver may be subject to system level ESD requirements

### Electromagnetic Interference (EMI)

Equipment incorporating gigabit transceivers is typically subject to regulation by the FCC in the United States, CENELEC EN55022 (CISPR 22) in Europe and VCCI in Japan. The WDP813-52C1 compliance to these standards is detailed in Table 2. The metal housing and shielded design of the WDP813-52C1 minimizes the EMI challenge facing the equipment designer.

### EMI Immunity (Susceptibility)

Due to its shielded design, the EMI immunity of the WDP813-52C1 exceeds typical industry standards.

Table 2: Regulatory compliance

Feature	Test Method	Performance
Electrostatic Discharge (ESD) to the Electrical Pins	MIL-STD-883C Method3015.7	Class 1 ( > 1500 Volts )
Electrostatic Discharge (ESD) tp the Duplex LC Receptacle	Variation of IEC 61000-4-2	Typically ,no damage occurs with 15KV when the duplex LC connector receptacle is contacted by a Human Body Model probe
Electrostatic Interference ( EMI )	CISPR22 ITE Class B EN55022 Class B FCC Class B	Compliant with standards
Immunity	IEC61000-4-3 Class 2 EN55024	Typically show no measurable effect from a 3V/m field swept from 80 to 1000MHZ applied to the transceiver without a chassis enclosure
ROHS Compliance		Less than 1000ppm of cadmium , lead, mercury, hexavalent chromium, polybrominated biphenyls, and ploybrominated biphenyl ethers.



## Digital Diagnostic Interface Definition

The 2-wire serial interface addresses of the sfp+ module are 1010000x (A0h) and 1010001x (A2h)

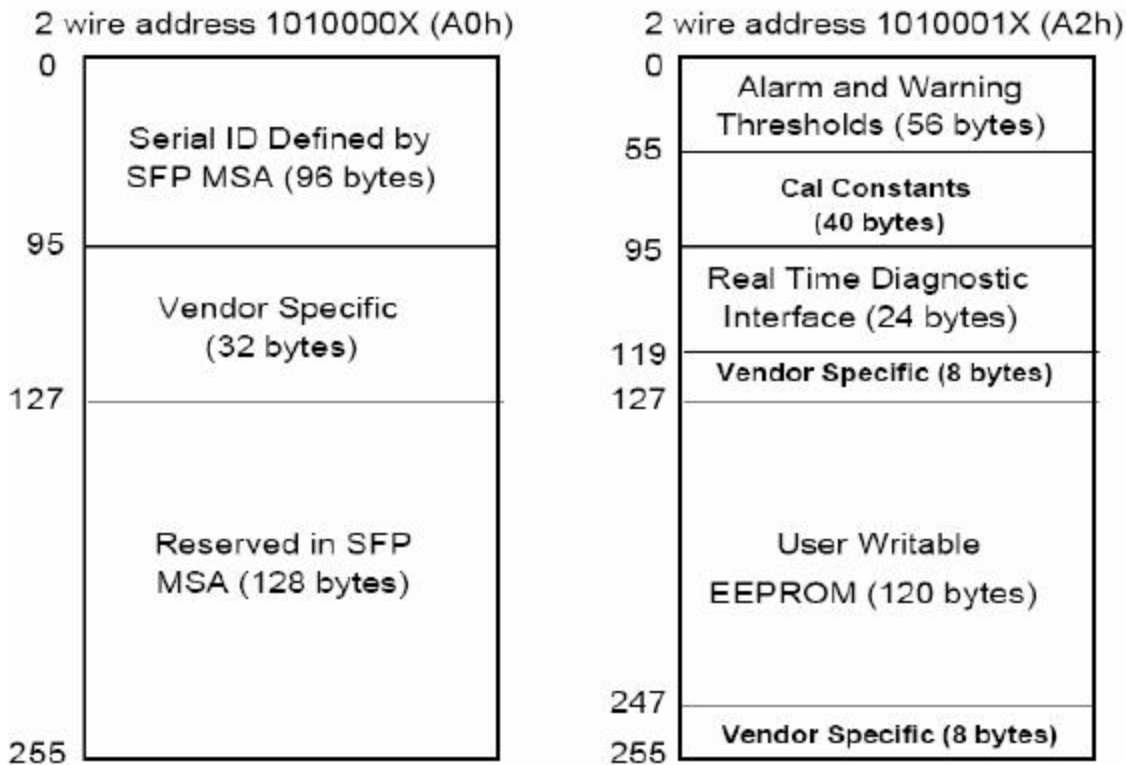

Accessing Serial ID memory uses the 2 wire address 1010000x(A0). Memory Contents of serial ID are shown in Table 3.

Table 3 : Serial ID memory Contents

Data Address	Size (Bytes)	Name of Field	Contents (Hex)	Description
<b>BASE ID FIELDS</b>				
0	1	Identifier	03	SFP
1	1	EXT. Identifier	04	SFP function is defined by Serial ID only
2	1	Connector	07	LC Connector
3--10	8	Transceiver		Transceiver Code
11	1	Encoding	03	NRZ
12	1	BR, Norminal	64	8.5-10.52Gbit/s
13	1	Reserved	00	
14	1	Length (9um, km)	00	Transceiver transmit Distance (300m)
15	1	Length (9um)	00	
16	1	Length (50um)	1E	
17	1	Length (62.5um)	1E	





18	1	Length(Copper)	00	
19	1	Reserved	00	
20--35	16	Vendor name		Net-Light(ASCII)
36	1	Reserved	00	
37--39	3	Vendor OUI	00 00 00	
40--55	16	Vendor PN		WDP813-52C1(ASC11)
56--59	4	Vendor REV	00 00 00 00	
60--61	2	Wavelength		Transceiver wavelength
62	1	Reserved	00	
63	1	CC_BASE	Check Sum	Check code for Base ID Fields
<b>EXTENDED ID FIELDS</b>				
64--65	2	Options	00 1A	TX_DISABLE TX_FAULT and Loss of Signal implemented
66	1	BR, max	00	
67	1	BR, min	00	
68--83	16	Vendor SN	31 32 33 34 35 36 37 38 20 20 20 20 20 20 20 20	Serial Number of transceiver (ASCII ). For example :12345678
84--91	8	Data code	30 35 31 30 31 31 20 20	Data code :051011
92	1	Diagnostic Monitoring Type	68	Diagnostics (EXT.Cal)
93	1	Enhanced Options	F6	Optional Alarm/Warning flags Implemented for all monitored quantities, optional soft tx_fault monitoring implemented , optional soft rx_los monitoring implemented
94	1	SFF-8472 Compliance	03	SFF-8472 Rev10.2
95	1	CC_EXT	Check Sum	Check sum for Extended ID Field
<b>VENDOR SPECIFIC ID FIELDS</b>				
96--127	32	Vendor Specific	Read only	Depends on customer information
128- 255	128	Reserved	Read only	Filled by zero



Package outline (unit:mm)

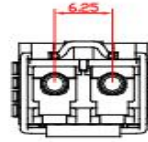
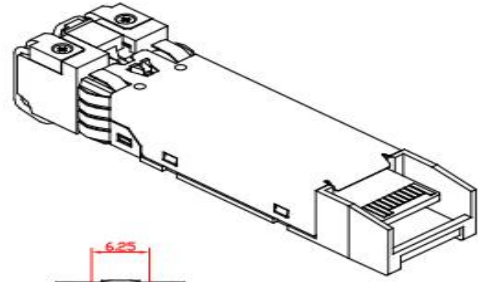
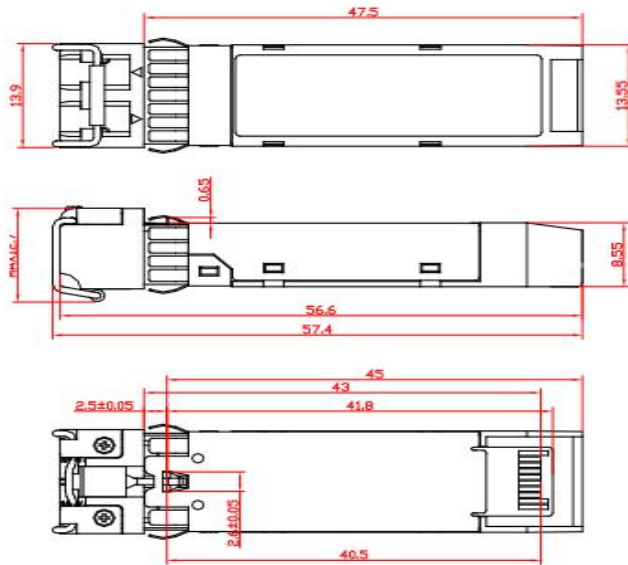

Unit: mm  
Unspecified Tolerance: ±0.1mm